

In-Line Duct Heater

Can be used to reheat air being delivered to the house from HRV (after heat recovery). Equipped with the most advanced Electronic Modulating Controller (SCR) and Air Flow Sensor to minimize operating cost.

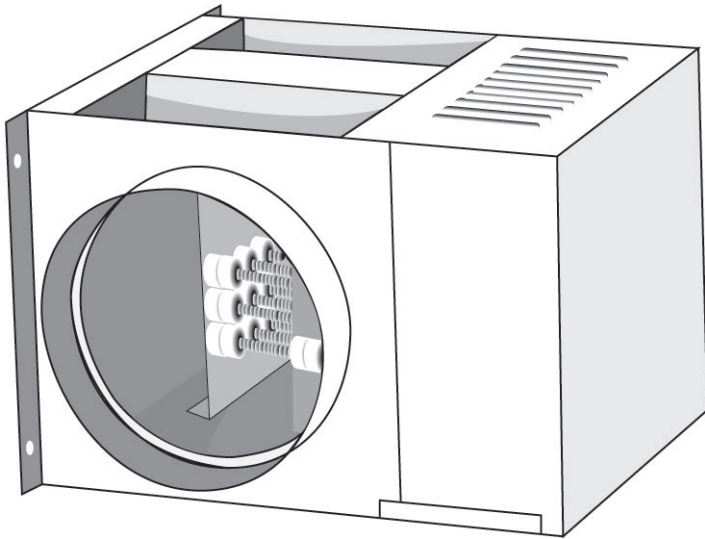

Features & benefits

- Automatic reset thermal cut-out is a safety feature preventing overheating: will reset automatically after cool-off.
- Manual reset thermal cut-out is an additional safety feature which prevents the frame from overheating.
- Open coil elements made of the highest grade nickel-chrome resistance wire, they will not age or oxidize, thus assuring longer heater life.
- Enclosure is made of corrosion resistant galvanized steel.
- Air flow sensor modulates the heating capacity according to the quantity of air flowing through the heater.
- Built-in electronic temperature controller and sensor proportionally modulates the heating load to match the exact capacity required minimizing operating cost.
- Round collars simplifies the installation and considerably reduces field labor.

Occasionally it may be desirable to reheat the air being delivered from the HRV to the occupied space. This will not effect the performance of the HRV as the duct heater will be installed in the fresh air delivered to the house (from HRV). This configuration allows the HRV to recover the maximum amount of heat possible. The in-line duct heater will then modulate the output required to reheat the air to the desired temperature.

Note: This type of system is generally only used when the HRV has a dedicated duct system (Figure 1). By using a dual core type HRV the need for an in-line duct heater may be reduced. This is an OPTIONAL device and is not needed in all instances.

Engineering Data

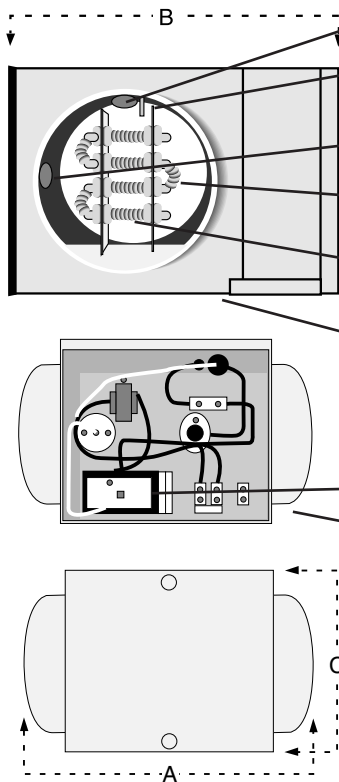

- Automatic Reset Thermal Cut-out
Safety feature preventing overheating: will reset automatically after cool-off.
- Air Flow Sensor
Modulates the heating capacity according to the quantity of air flowing through the heater.
- Manual Reset Thermal Cut-out
Additional safety feature which prevents the frame from overheating.
- Temperature Sensor
Controls the heater proportionally to maintain the pre-set air temperature in the duct.
- Open Coil Elements
Made of the highest grade nickel-chrome resistance wire, they will not age or oxidize, thus assuring longer heater life.
- Enclosure
Corrosion resistant galvanized steel.
- Built-in Electronic Temperature Controller and Sensor
Proportionally modulates the heating load to match the exact capacity required, thus minimizing operating cost.
- Round Collars
Simplifies the installation and considerably reduces field labor.

| DIA | A | B | C |
|-----|--------|--------|-------|
| 6" | 12.50" | 11.50" | 8.50" |
| 7" | 12.50" | 11.50" | 8.50" |

| Part # | Collar Size | Kw | Voltage | Amps | Min CFM |
|--------|-------------|----|---------|------|---------|
| 99-163 | 6" | 1 | 120/1 | 8.3 | 10 |
| 99-164 | 6" | 2 | 120/1 | 16.7 | 20 |
| 99-160 | 7" | 1 | 120/1 | 8.3 | 10 |
| 99-161 | 7" | 2 | 120/1 | 16.7 | 20 |

*Special order In Line Duct Heaters also available.

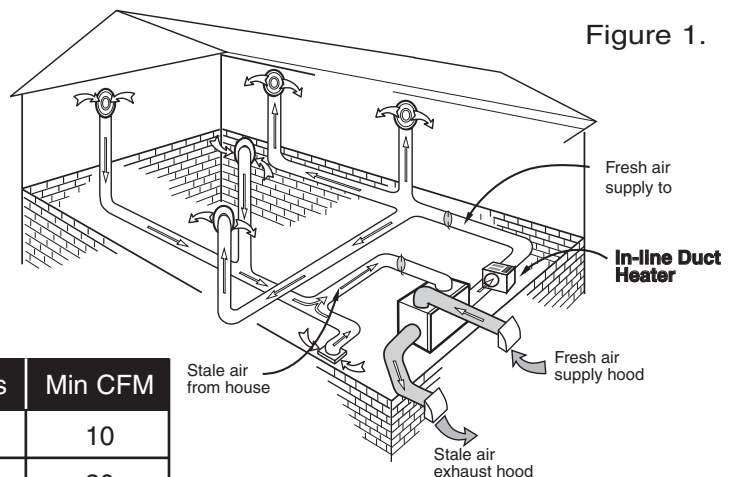

Figure 1.

To calculate make up heat requirements:

1. Calculate temperature of air being delivered from HRV

$$\left[\frac{\text{HRV effectiveness}}{100} \right] (T3 - T1) + T1 = T2$$
2. Calculate make-up heat requirements.
 - a. $\text{CFM} \times 1.08 \times (T3 - T2) = \text{BTUH}$
 - b. $\frac{\text{BTUH}}{3.413} = \text{Watts}$
 - c. $\frac{\text{Watts}}{1000} = \text{KW}$

Where T1 = Outdoor design temperature (Cold air intake)
 T2 = Air delivered by HRV (Fresh air supply)
 T3 = Indoor design temperature (Warm stale air)



511 McCormick Blvd.
 London, Ontario N5W 4C8
 T (519) 457-1904
 F (519) 457-1676
 Email: info@lifebreath.com

270 Regency Ridge, Suite 210
 Dayton, Ohio 45459
 T (937) 439-6676
 F (937) 439-6685
 Website: www.lifebreath.com

