



Quantum

INLINE FAN SERIES

4", 5" OR 6" DRYER BOOSTER KIT WITH CURRENT SENSING CONTROL

Model 99-TI-DBK-COMBI-001

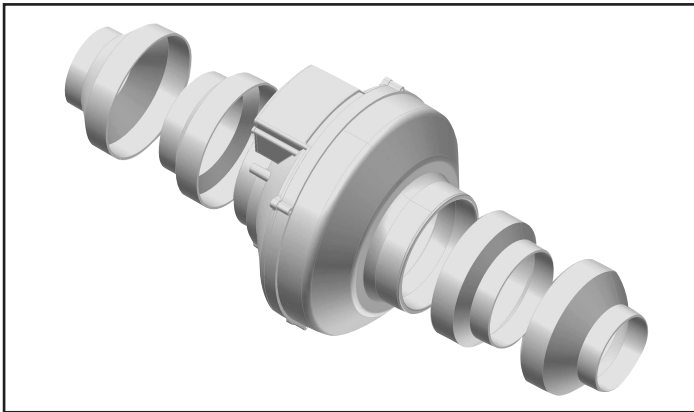

Model 99-TI-DBK-COMBI-001

General

Before installation, careful consideration must be given to how this system will operate if connected to any other piece of mechanical equipment. It is always important to assess how the operation of any air movement device may interact with vented combustion equipment (i.e. Gas Furnaces, Oil Furnaces, Wood Stoves, etc.).

NEVER install a ventilator in a situation where its normal operation, lack of operation or partial failure may result in the backdrafting or improper functioning of vented combustion equipment without proper safety/warning devices installed as required.

Table of Contents

General	1
Table of Contents	1
Specifications	2
Assembly	3-4
Installation	5
Mounting	5
Dryer Booster System Installation Details	6
Troubleshooting	8
Maintenance	8

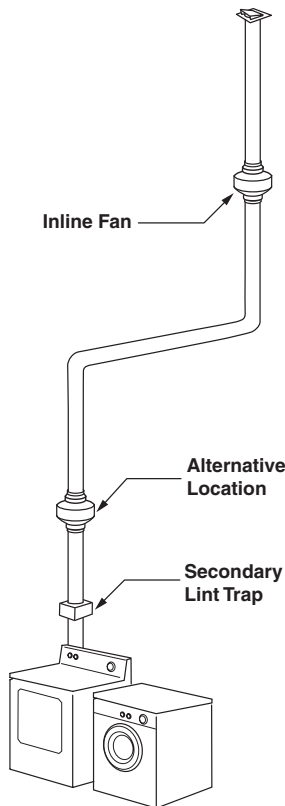

ATTENTION

Do not exhaust air in excess of 60°C / 140°F.



Airia Quantum Series Inline fans are approved for both Residential and Commercial applications. The superior plastic resin is suitable for applications requiring fire rated materials and provides a quiet, weatherproof, versatile fan.

Plastic fans are suitable for indoor OR outdoor installations and are suitable for temperatures of -40°F (-40°C) to 140°F (60°C).

⚠ WARNING

Do not use fan where water can/will accumulate inside fan housing. When required – always use suitable electrical connections to prevent water from entering the fan housing.

⚠ CAUTION

For general ventilation only. DO NOT use this fan to exhaust hazardous or explosive material and vapors.

NBQ-COMBI-456 - Field Selectable 4", 5" or 6"

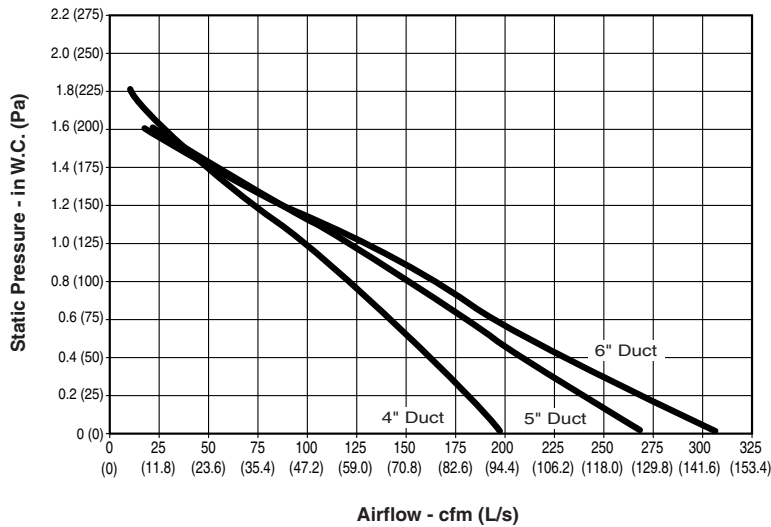

Model 99-NBQCOMBI-456
Field Selectable 4", 5", or 6"

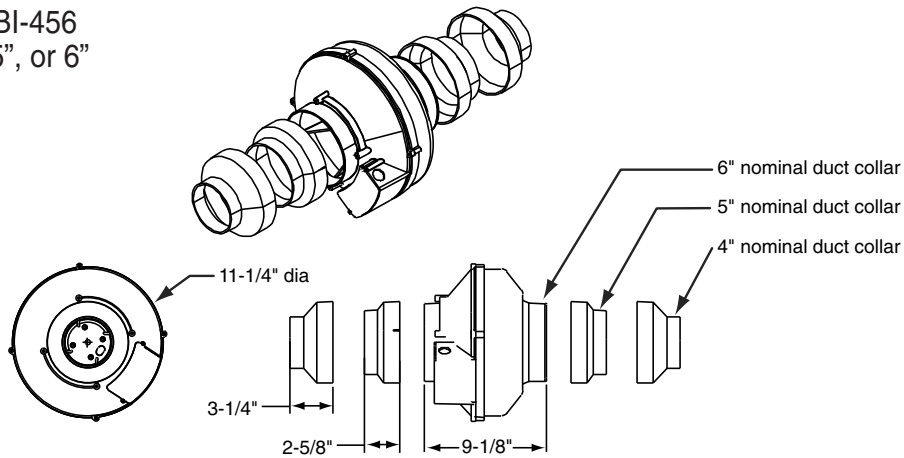

Assembly

The unique COMBI fan can be configured in either 4 inch, 5 inch, 6 inch, OR any combination of the three.

The collars will fit on the main housing with a tapered friction fit. No sealant is required. Locate screw slot on collar and use 1 - 1/4" hex head screw (supplied) per collar to secure collar in place.

Collars included with this fan

- 2 – 4" collars
- 2 – 5" collars

The following configurations are available:

Six Inch Dedicated (no collars required)

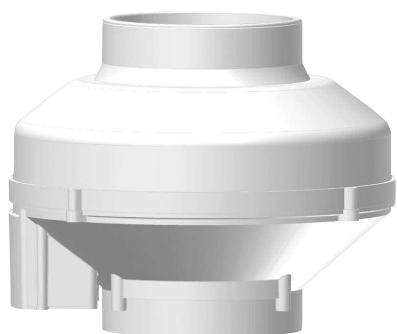

Five Inch Dedicated (attach 2 - 5" collars)

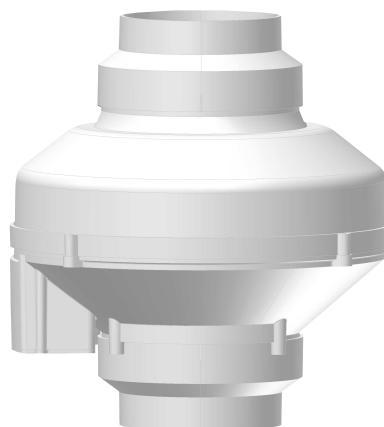
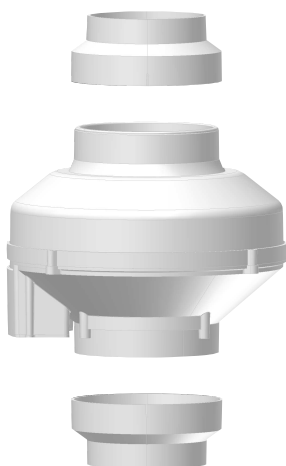

Four Inch Dedicated (attach 2 – 4" collars)

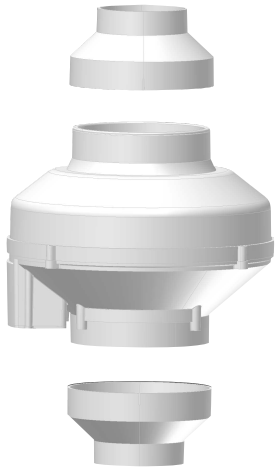

Combination

Example -- 4 inch and 5 inch collars. Any combination of sizes can be used.

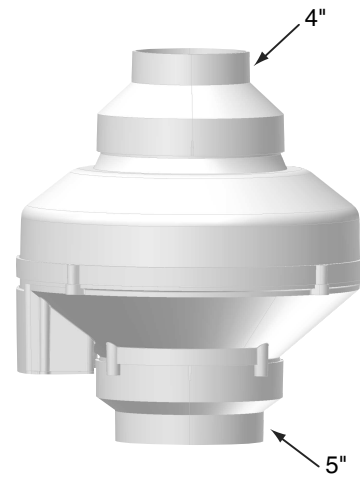
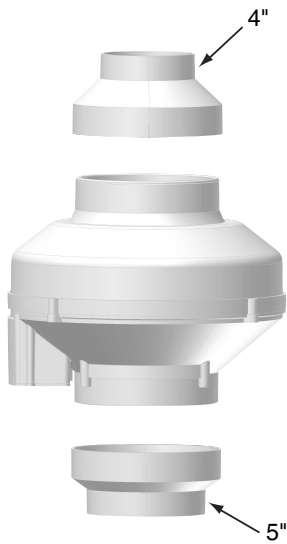

Installation

Mounting

Fans can be mounted in ANY position (vertical, horizontal, or diagonal).

Option 1

A mounting bracket is included for securing the fan. Please observe the mounting 'bosses' on one end of the fan. All necessary hardware is included for mounting the fan with the supplied bracket (see Figure 1).

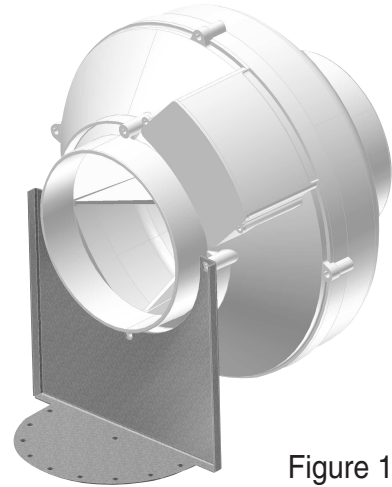

Figure 1

Option 2

Optional Stabilizing Mounting Clamps are available for mounting the fan. These clamps are designed to absorb mechanical vibration and provide a stable mounting point (see Figure 2).

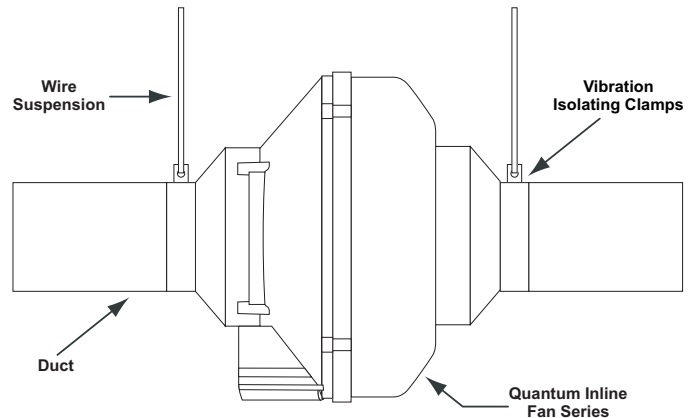

Figure 2

Option 3

The fan can be supported using standard hanging straps as illustrated. It is recommended to use a short piece of flexible ducting on each end of the fan to isolate any mechanical vibration. (see Figure 3).

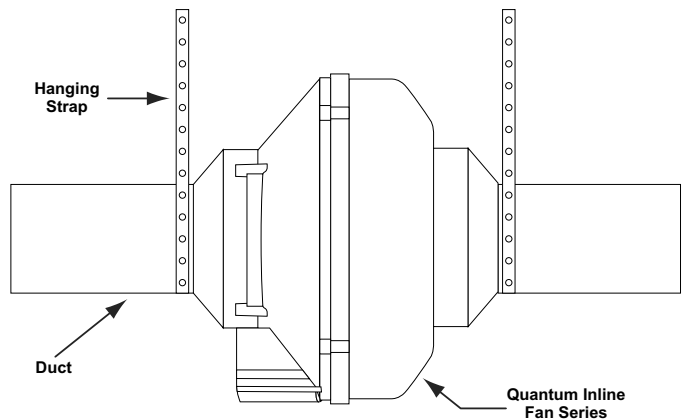

Figure 3

Dryer Booster System Installation Details

Included in Kit:

- 1 Booster Fan
- 1 Fan Mounting Bracket and Hardware
- 1 Current Sensing Switch

Installation Guidelines

Fan and Switch Mounting

The recommended location of the booster fan is a minimum of 15 linear (not equivalent) feet of duct from the dryer outlet. If the fan is mounted closer than the recommended 15 feet, it may develop enough pressure to lift wet lint into the fan impeller resulting in excessive lint loading in the fan. The best location for the fan to be mounted is as close as possible to the termination of the duct work.

(Exception: If a secondary lint filter is installed between the dryer and the booster fan, the booster fan may be mounted within the minimum distance otherwise recommended. See illustration to the right.) Mounting bracket attached to a rafter or joist should be used to stabilize the fan. Although not recommended, a vertical rigid duct may support the fan if the duct is securely stabilized. (Consult local codes prior to supporting the fan in the duct alone.) Duct work should be attached to the inlet and the outlet of the fan by means of vibration isolation clamps (not included) or duct tape. The duct connection should be properly sealed to prevent leakage and loss of fan performance. Flex duct connections (if dryer manufacturer recommendations permit) between the dryer duct connection and exhaust duct should be stretched as smooth as possible.

Fan Installation

Step 1: Selecting a Fan Location

The recommended location of the booster fan is a minimum of 15 linear (not equivalent) feet of duct from the dryer outlet. If the fan is mounted closer than the recommended 15 feet, it may develop enough pressure to lift wet lint into the fan impeller resulting in excessive lint loading in the fan. The best location for the fan to be mounted is as close as possible to the termination of the duct work. In order to perform recommended maintenance, fan location should allow sufficient access for service. Refer to dimensional drawings shown above.

Important Notice! To prevent the possibility of dryer fan exhausting excess heat required for the drying cycle and compromising drying times, booster fan airflow must not exceed dryer fan capacity.

Please Note: Fans are not explosion proof. Do not use the fans if a potentially explosive situation may exist.

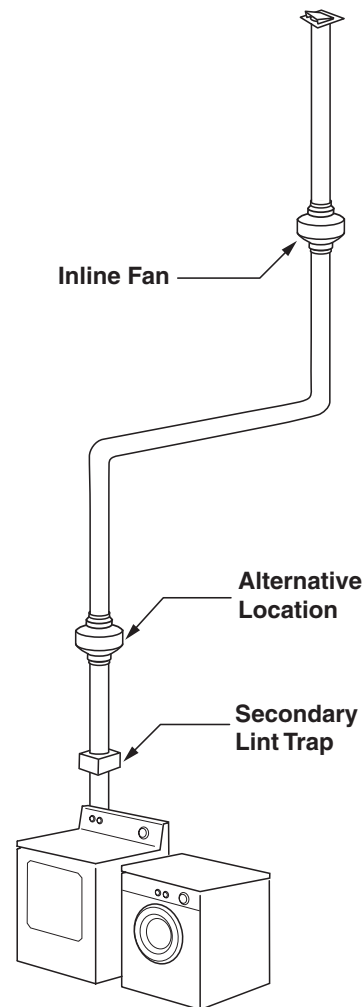

⚠ WARNING

Turn power off at circuit breaker or fuse panel.

Installation Type 1 (at dryer junction box)

1. Attach electrical junction box to the dryer junction box.
2. Disconnect and loop neutral (white) dryer power supply wire through centre of sensor then back to the dryer junction box and re-connect.
3. Mount sensor in the electrical box (two holes may have to be drilled for mounting).
4. Connect fan 120V AC power supply to the top (relay) terminals of the sensor.

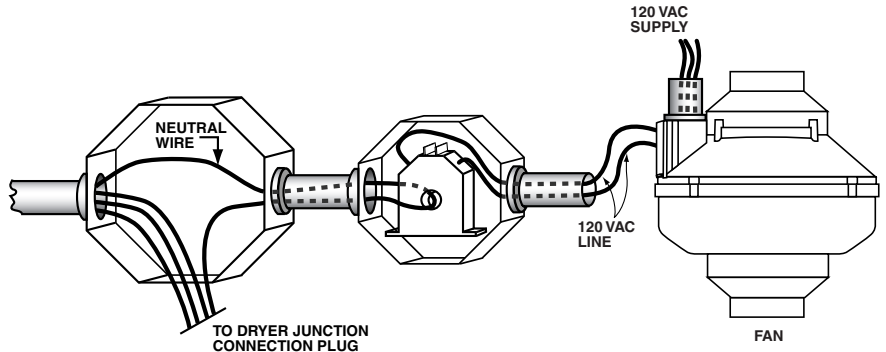

Installation Type 2 (at fuse/breaker panel)

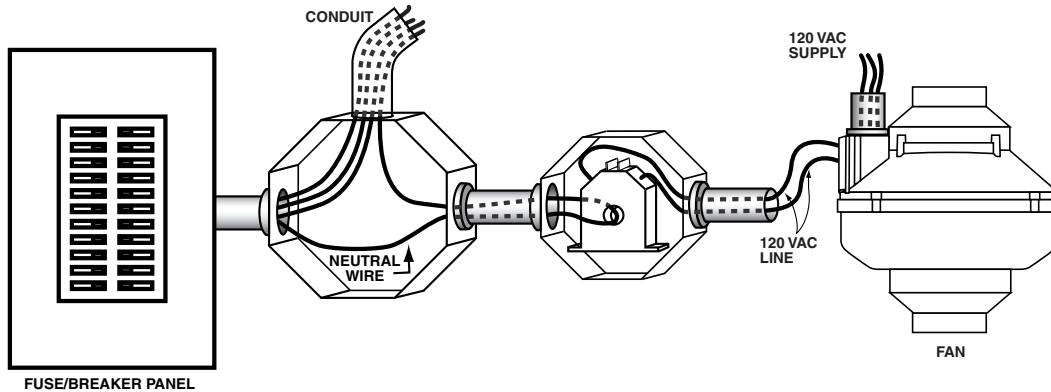

1. Mount sensor at a convenient location on the fuse/breaker panel.
2. Disconnect and loop neutral (white) dryer power supply wire through centre of sensor then re-connect.
3. Connect fan 120V AC power supply to the top (relay) terminals of the sensor.

Installation Type 3 (inside dryer compartment)

1. Mount sensor in a convenient location inside the dryer connection compartment.
2. Disconnect and loop neutral (white) dryer power supply wire through centre then re-connect.
3. Connect fan 120V AC power supply to the top (relay) terminals of the sensor.

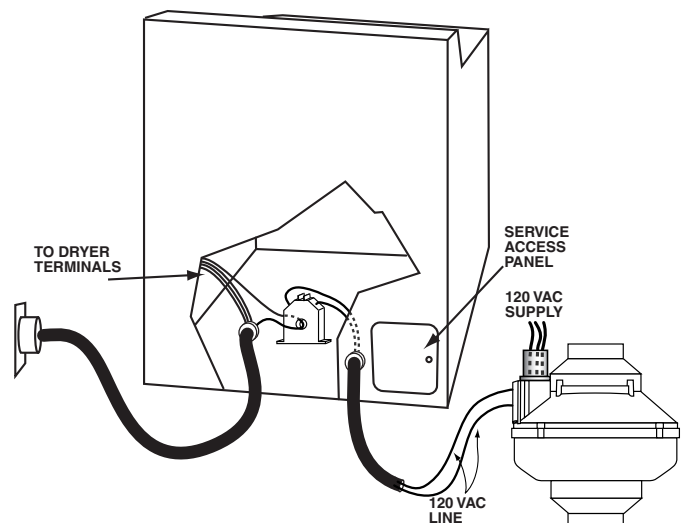

Troubleshooting

- Use a multimeter to verify a 120 VAC supply to motor.
- Check wiring diagram to ensure proper connections.
- Use a multimeter to test continuity to motor.
- Disconnect capacitor and check capacitor with a multimeter.

CAUTION

Disconnect all power sources before attempting any service.

Maintenance

- Fan bearings are sealed and have an internal lubricant, so no lubrication is required.
- Once per year, remove any dust/dirt and debris from the impeller.
- Check lint trap regularly! Excessive lint accumulation will block airflow.



511 McCormick Blvd.
London, Ontario N5W 4C8
T (519) 457-1904
F (519) 457-1676
Email: info@lifebreath.com

270 Regency Ridge, Suite 210
Dayton, Ohio 45459
T (937) 439-6676
F (937) 439-6685
Website: www.lifebreath.com

